

Productivity

"Proven pre-engineered design and options for the fastest response to meet your packaging needs."

Automatic Straddle
Stretch Wrapping System



S-1200

pallet-grip®

- Patented "Lock Your Load to the Pallet" System
- Reduce Load Shifting
- Reduce Product Damage

S-1200 Automated System

- Wrap 30-45 loads per hour.
- More than 75 pre-engineered options to meet your application needs.
- Install over existing conveyor.
- Lantech quality at entry level price.
- Based on the robust S-Series stretch wrapper design.



S-1200



Allen-Bradley safety signal light and horn.



Allen-Bradley standard devices throughout the control enclosure to facilitate local sourcing.

Entry Level Price - Premium Quality

- Interlocked safety fence included.
- 3 year unlimited cycle warranty.
- Pre-wired for fast set up.
- Belt drives standard.
- Patented Power Roller-Stretch® film delivery system.
- Includes Lantech exclusive Lan-Logix operator control.

Pre-Engineered Options

- No engineering required gives you quicker delivery.
- Pre-engineered means "Tested Tough".
- Control drawing available at the time of order entry.
- Design based on over 50,000 applications in the field.

Load Seeking Clamp

- Exclusive clamp "seeks out" load & holds film against the load
- Eliminates beginning film tails
- Improves containment

Lan-Logix™

The Lan-Logix interface leads the industry to boost productivity by eliminating the need for costly software and hardware to make minor program changes. Included are multiple wrap patterns, precise wrap pattern control, password protection, and extensive efficiency data capture.



S-1200 Specifications

PERFORMANCE CRITERIA	S-1200
<ul style="list-style-type: none"> ■ Production Speed based on 80" load height; 2 film layers and 12 revolutions ■ Maximum Load Size 	30-45 loads per hour 58"L x 58"W x 80"H (Requires optional 60" EW conveyor system)
FILM DELIVERY SYSTEM <ul style="list-style-type: none"> ■ Power Roller-Stretch® ■ Wrapping Force ■ Pallet-Grip 	200% Stretch (Std) 100-300% available Electronically controlled Standard
PNEUMATIC DATA <ul style="list-style-type: none"> ■ 3-5 CFM @ 80 psi clean, dry air 	Standard
MACHINE SHIPPING WEIGHT <ul style="list-style-type: none"> ■ Shipping Weight (including skid - approximate) 	3500 lbs. (w/o conveyor)
ELECTRICAL DATA <ul style="list-style-type: none"> ■ Voltage ■ System Logic ■ NEMA 12 enclosure 	230V PLC/Touchscreen Standard
SERVICE SUPPORT	24hrs/7 days a week

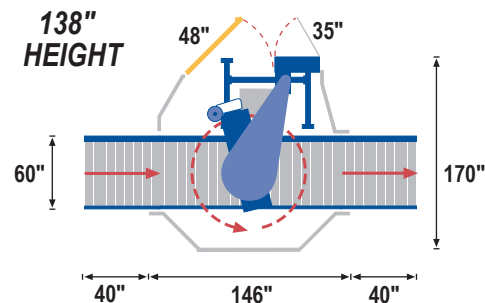

Specifications subject to change without notice. Lantech systems and sub-systems are protected by U.S. and foreign patents. Additional U.S. and foreign patents pending. © Lantech.com 2008

